

WOOD ELEMENTS IN BUILDING STRUCTURES

Marchenko N.V., Candidate of Science

National University of Life and Environmental Sciences of Ukraine

The state, trends and problems of using elements of wood constructions in modern construction. The presence of any significant effect size prototypes and wood defects on stress distribution in arboreal constructions.

Elements of wooden structures, calculated properties of wood.

Formulation of the research problem. During the development of new building materials and construction specialists to start focusing on their performance properties [1]. Criteria such as environmental or consumption of raw materials and energy away first by the wayside. However, they play a very prominent role, as largely dictate the market price of the new material. That is why the interest in traditional materials based on renewable raw materials, which is a typical example of wood, is increasing rapidly. With new technologies beams can now, in many cases compete with metals, polymers and even ceramics [1].

The aim of the research is to establish design characteristics of timber for use in cell structures. For this first stage of work was used analytical methods research.

Results. Elements of wood belonging to the class of light structures, the use of which in construction is one of the important directions of ways to improve the construction of production [2]. Wood construction buildings serve as decking, beams, purlins, racks, trusses, arches and frames, wall elements, etc. (figure 1 – figure 5).

The advantages of wood as a building material is needed for strength light weight, sufficient durability, the relative ease of procurement of material and technology of production structures, small values of the coefficients of thermal expansion and thermal conductivity, resistance to the most common chemically aggressive environments. However, the biggest advantage of wood today is what it is - the only stuff that self-healing on the Earth's surface under the influence of

Solar energy. The main disadvantages are low resistance, biological stability, additive mechanical-and-physical properties on temperature and humidity application conditions and period of loading, significant heterogeneity [4].

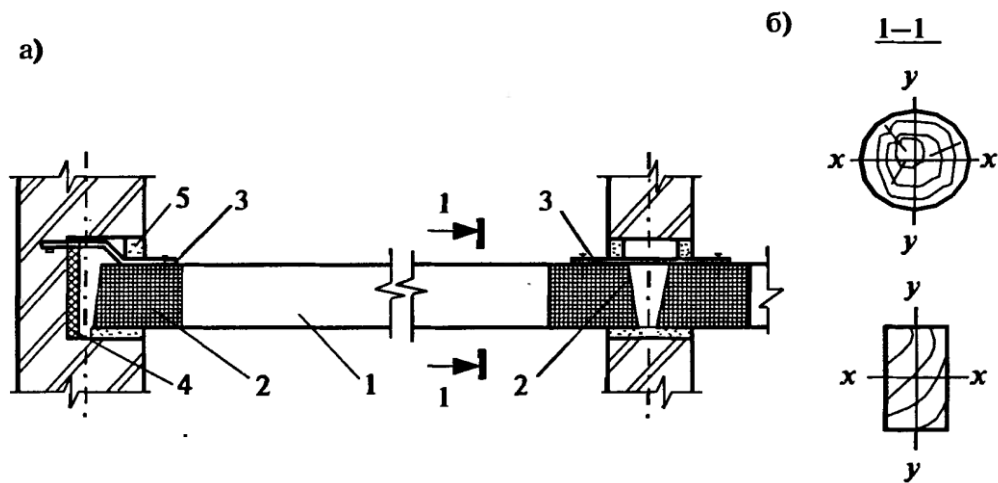

Figure 1. Placing the wooden beams of solid wood in a brick wall, where: a – massive beams leaning on wall; b – sections of beams; 1 – beam; 2 – toll layers; 3 – steel anchor; 4 – insulation; 5 – sand-cement mortar [3]

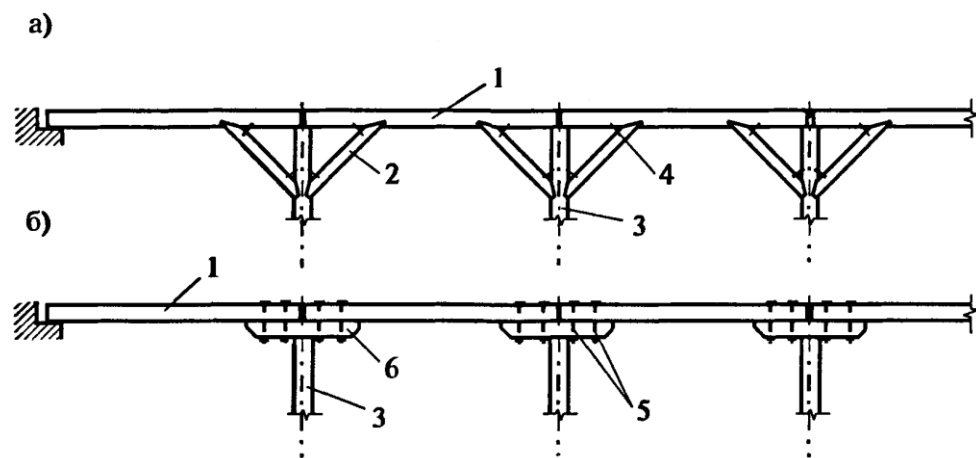

Figure 2. Schemes wooden purlins, where: a – discontinuous runs with struts; b – discontinuous runs with hammer-beams; 1 – chief beam; 2 – strut; 3 – stay brace; 4 – timber dog; 5 – packing bolt; 6 – hammer-beam [3]

Wood structures [5] are made of raw conifers and hardwoods that may be in the form of round timber with diameter of 11 cm and a thickness of sawn 16 mm. Width of annual layers of wood must be no more than 5 mm, and their content of late wood – at least 20%. Softwood characterized by straightforwardness, better

than hardwood, mechanical properties and greater resistance to decay due resinousness. Solid hardwoods (oak, beech, hornbeam, etc.) used in the designs are often responsible for making the small details – false tongues, timber connectors, etc. Soft hardwoods (aspen, alder, poplar) are used for the construction of temporary structures, support structures and formwork. [6]

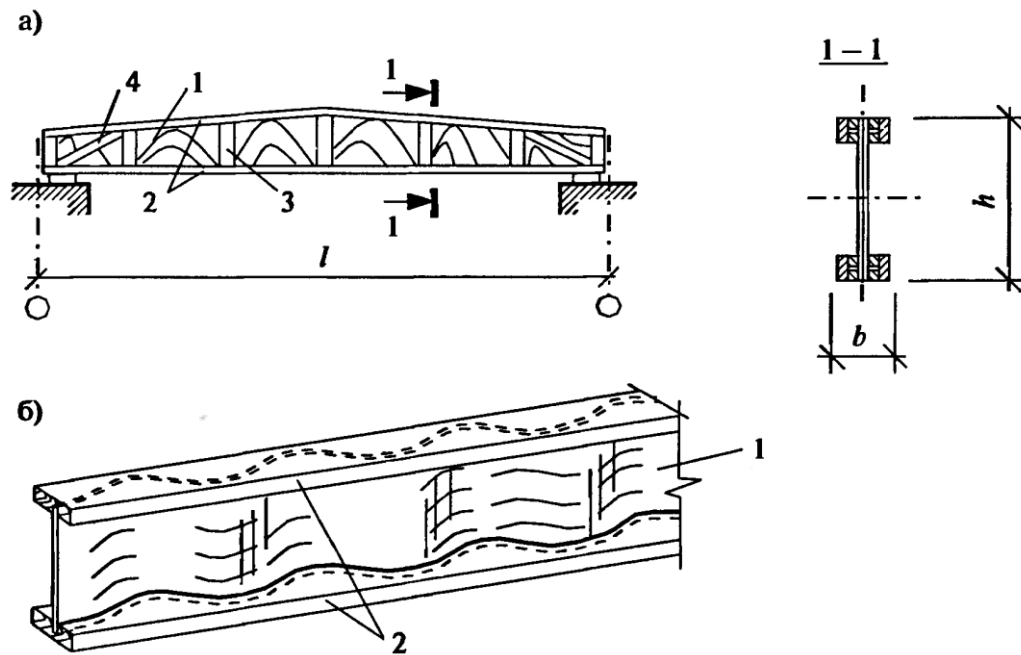

Figure 3. Wooden beams with plywood racks, where: a – glulam beams from sustainable plywood flat; b – beam with corrugated resistant plywood; 1 – plywood rack; 2 – beams boom, 3 – stiffening fins; 4 – bearing beam [3]

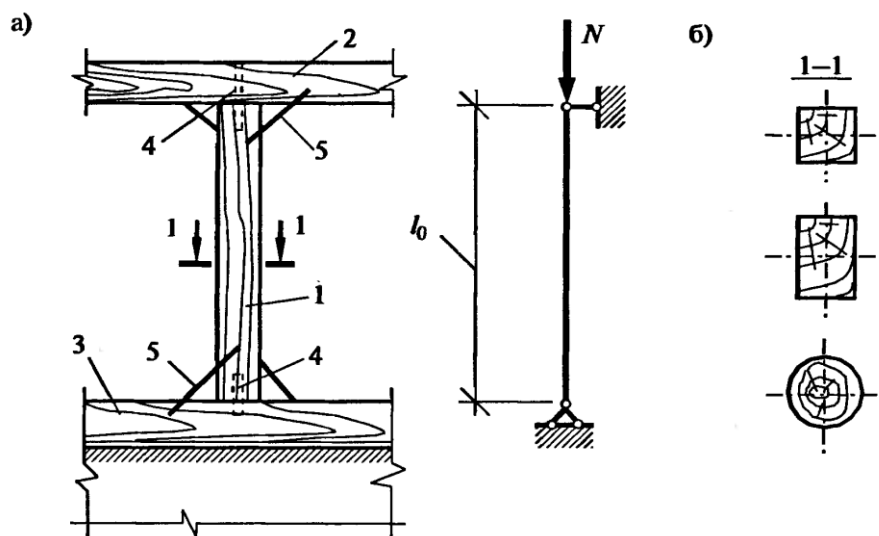

Figure 4. Wooden rack in column-beam system, where: a – pillar structures and its design scheme; b – profile solid beams boom; 1 – compression strut; 2 - hammer beam; 3 – groundsill; 4 – cup hook nail; 5 – timber dog [3]

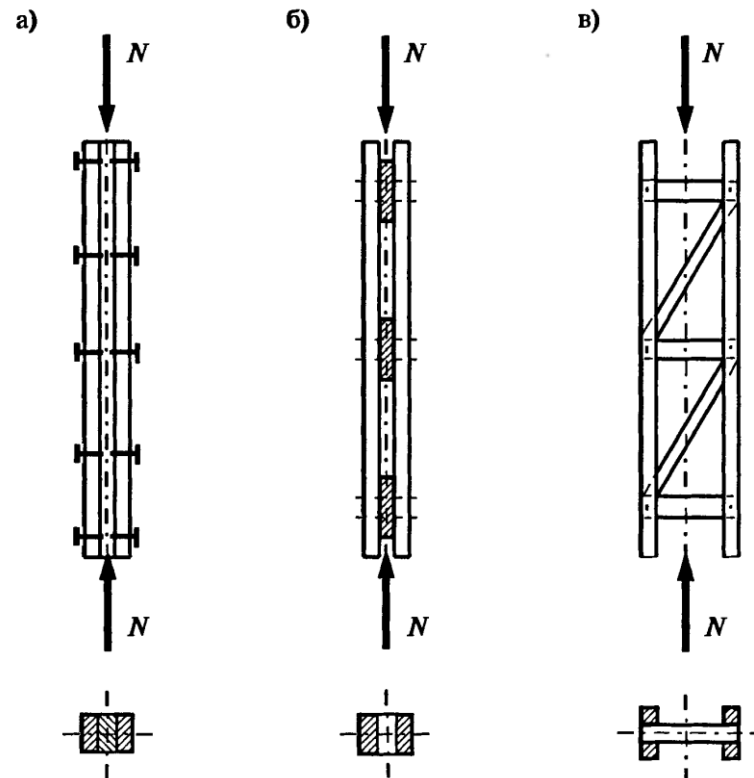

Figure 5. Auxiliary's bar built-up section, where: a – auxiliary bar with stack board; б – auxiliary bar with short retainer seals; в – auxiliary bar with open gating[3]

Scope of wooden structures depends on their economic efficiency, determined by comparing the different options of design decisions. Based glued wooden structures built building with coatings of both small and large spans. With round and sawn timber built small houses, public and industrial buildings. Economic efficiency wood housing provided structural optimization, simplification of installation, shortening the construction of facilities and low emissions. For example, due to the fact that the wooden construction is quite easy, then *ceteris paribus* their weight may be about 5 times less compared to steel and concrete structures, providing cost savings during assembly and transport of [7].

The most important characteristic of wood as a material for building structures is its ability to resist destruction from the effects of variable loads. Job content depends on the type of loading (tension, compression, bending, shearing,

crushing), the direction of action with respect to the efforts of wood fibers, etc. [3, 5, 6].

In the design of wooden structures in accordance with building codes and regulations SNIP II-25-80 [5] used in the calculations is not tensile strength of small samples of wood and several times smaller figures – calculated support. They take into account the large size of structural elements, the presence of defects wood variability of its properties, the duration of the load, humidity, temperature and other factors. For certain values of the strength of materials according to [5] calculated limit state designs, provided that they fail to meet specified performance requirements for durability and structural integrity.

Regulatory resistance is determined by the expression [5]:

$$R_H = R_{bp}(1 - 1,65 \times v) \quad (1)$$

Where v – coefficient of variation of strength according to the test; R_{bp} – temporary value of the material (average distribution), MPa; 1,65 – quantile of a predictable statistical distribution function of the supply of 0,95, which is defined for regulatory resistance.

Calculated R_p support is determined by the formula:

$$R_p = \frac{R_H \times m_{\eta r}}{\gamma_m \times \gamma_H} \quad (2)$$

On the condition of 0,99 with regard to the material safety factor γ_m which is determined by the transition from R to supply 0,95 to 0,99 for the provision of R_p (2,33) by the expression:

$$\gamma_m \geq \frac{1 - \eta_n \times v}{1 - \eta_p \times v} \quad (3)$$

Where η_n , η_r – fractile for provision 0,95 for R_H (1,65) and for supply 0,99 of R_p (2,33); v – coefficient of variation; γ_H – safety factor to account responsibility ($\gamma_{H(0)}$) and lifetime ($\gamma_{H(cc)}$) designs.

Thus, the compression along the grain and static bending resistance calculated base wood of pine and spruce is 8 – 16 MPa (depending on the type of wood). Basic parameters passed multiplied by a number of factors, which take into account the breed and condition of the material conditions of his work in the

design. If the load is applied to the design element that is in high humidity, the calculated resistance multiplied by reducing 0,75-0,9 factors, the impact of high temperature into account factors 0,8-1,0. In the case where there are intermittent sources (wind, seismic) loading, calculated by multiplying the increasing reliance on ratios 1,2-1,6. Joint effects of permanent and temporary long loads into account the coefficient of 0,8.

The elastic modulus along and across the grain of wood of all species taken as equal to, respectively, 10 GPa and 400 MPa. Shear modulus in the plane along the grain – 500 MPa. Odds transverse deformation in the event of effort along and across the grain receiving, respectively, at 0,5 and 0,2.

Today, however, these rates are subject to revision [7], because they found a significant error in the direction of increasing the calculated resistances. Also, found [8] that the calculated support content depend on the absolute and relative sizes of wooden elements: reducing the resistance of conventional building elements in relation to the size of small resistance standard samples is 15-25%, the tensile strength of large samples by an average of 27 % lower than small ones. The heterogeneity of the structure of wood, which is more pronounced in larger specimens, reduces the tensile resistance along the grain by 12% -15%, and the presence in these samples even small defects wood resistance is reduced to 25% compared with small test specimens.

Conclusions. Established, that in the process of determining the design characteristics of wood for use in cell structures should consider the impact of the absolute size of the samples by entering the factor dimension reduction, that evaluates the carrying capacity of large samples in relation gives small or conduct research strength of wood structures on samples of model building size, features at the intersection.

We found that the current regulations [5] provides temporary support to determine the results of tests of small samples sawn and sawn samples for field size and round timber, which also provides for use in building structures research methodology and standard resistance value not established.

References

1. Фрадкин В. Древесина – материал будущего / В.Фрадкин // N-T.ru - электронная библиотека. Техника сегодня. Электронный ресурс: режим доступа <http://n-t.ru/tp/ts/dr.htm>.

2. Мелехов В.И. Прочностные характеристики пиломатериалов небольших сечений в строительных конструкциях / В.И.Мелехов, В.Е.Бызов // Хвойные бореальной зоны, XXVI. – 2010. – № 3-4. – с.366-370.

3. Сетков В.И. Строительные конструкции. Расчет и проектирование: учебник / В.И.Сетков, Е.П.Сербин. – М.: Инфра-М, 2005. – 448с.

4. Ковальчук Л.М. Обеспечение эксплуатационной надежности деревянных конструкций / Л.М.Ковальчук // Деревообрабатывающая промышленность. – 2008. – № 1. – с.10-12.

5. Пособие по проектированию деревянных конструкций (к СНиП II-25-80) / ЦНИИСК им. Кучеренко. – М.: Стройиздат, 1986.

6. Калугин А.В. Деревянные конструкции. Учебное пособие / А.В.Калугин – М.: Изд-во АСВ, 2003. – 224 с.

7. Серов Е.Н. Клееные деревянные конструкции: состояние и проблемы развития / Е.Н.Серов, Б.В.Лабудин // Лесной журнал. – 2013. – № 2. – с.72-78.

8. Серов Е.Н. Особенности разрушения стандартных образцов и их связь с работой конструкций // Лесн. журн. – 1994. – № 1. – с. 75-79.

Рассмотрено состояние, тенденции и проблемы использования элементов древесных конструкций (ДК) в современном строительстве. Установлено наличие существенного влияния размеров опытных образцов и пороков древесины на распределение напряжений в ДК.

Элементы деревянных конструкций, расчетные характеристики древесины.