

In paper was proposed the concept of study the mechanics and mechanisms of interaction of vibrational tillage tools with the soil.

Concept, research, mechanical, mechanisms, interaction, elastic suspension, soil.

UDC 631,311: 621,891

STATE AND PROSPECTS FOR STRENGTHENING AND REPAIR OF AGRICULTURAL MACHINES WORKING IN UKRAINE

***VD Voytyuk, PhD
N. Denisenko, Ph.D.
A. Opalchuk, PhD***

The article given analytical review of existing methods of strengthening and restoration work of agricultural machinery, are the types of wear parts and components; Proposals production.

Working bodies tillage machines, abrasive wear, disc harrows paw cultivator, plow ploughshare.

Formulation of the problem. Techno-economic performance of many agricultural machines still very low due to the small length of service of their workers and forced outages

© VD Voytyuk, MI Denisenko, A. Opalchuk, 2015

at the last periodic replacement, which requires a significant investment of funds for repairs and spare parts. In particular this applies tillage implements, operating agencies which operate in difficult field conditions at considerable stress, shock, vibration, warps. Rapid wear blades plowshares, paws cultivators and disc harrows reduces the productivity of units and the quality of performance and, ultimately, to increase the cost of agricultural products. In southern Ukraine paws dry areas and cultivators Ploughshares have to repair or replace thatchanges. Thus on sandy soil worn details 8-10 times faster than clay. Ploughshare plow is one of the most wear working bodies. The main reason - the rapid abrasive wear caused by the interaction of solid (NV 8-11 GPa) mineral particles contained in the soil .. At the present time for the main cultivation - plowing used parts of the job, structural parameters were designed 40 ... 50 years back. Given that to date has significantly increased the mass harvesting machines, which led to an increase in the density of the soil, the load on the working bodies of arable units increased about 4 times, although the working

bodies have not changed either structurally or in the material science area.

Numerous test series working bodies blade plows show that the average time between failures dolotopodibnyh plowshares P-702 depending on the types of soils and their physical condition ranges from 5 to 20 hectares sternum shelves - from 10 to 100 hectares, wings shelves - from 40 to 270 hectares of field boards - from 20 to 60 hectares [1]. Limited resources are working bodies and other tillage machines: plows and disc harrows disc - 8 ... 20 hectares, feet cultivators - 7 ... 18 hectares. All this shows that the durability of the job tillage machines not sufficient. So research aimed at improving their life are important and are of great national importance.

Analysis of recent research. Great contribution to research into the work wear of machines and the development of measures to improve their work ability and durability have made foreign and domestic scientists: M. Tenenbaum, N. Khrushchev, Severnyev M., A. Rabinovich S., KRAGELSKY IV, KostECKI BI, Tkachev VN, Bernstein DB, Lorenz VF, Lvov PN, Kushnarev A. Boyko AI and many others. Differential selection of materials and the development of construction work increased longevity requires a detailed classification of soils by wearing their ability. The main elements of the wear is hard (NV 7 ... 11 GPa) mineral particles of quartz and granite, which make up about 36.6 ... 70.8% of the soil. Then the degree of distribution are feldspar, mica and other materials (NV 6 ... 7.2 GPa). The greater the number of particles having a rounded shape, but also the present and the particles that have sharp edges and protrusions capable deform and wear contact surfaces of parts working bodies.

When plowing hitting obstacles as rocks, soil sealing and solid areas increases the load on the opener "tovchkamy": 0,04-0,1 seconds for 10 times or more compared to its average over the normal plowing [2]. This is a great danger to the durability of all components of the plow, in the first place - blade. Methods for increasing the durability of working parts can be divided into the following groups: 1) the chemical composition and properties of the material; 2) heat treatment; 3) surface chemical and thermal strengthening; 4) solid surfacing alloys; 5) the use of metal powder materials [2, 3]. In the literature there is little justification for the choice of these materials. Obviously, the main criterion they use is strength in the dangerous section. In published works focused on the improvement of thermal processing plowshares and similar working bodies. According to JH Ermakova [4] The wear resistance of iron plowshares 10-30% greater than steel. Industrial use in our country is not found, although in the UK for the treatment of light soils used iron plowshares with bottom side bleached for over 150 years. The

widespread use of technology renewal and strengthening Ploughshares ceramic materials held high cost of production pottery and ceramics lack the technology to mount blade that provides the necessary clutch ceramic plate with a plowshare. Existing methods and materials for restoration and strengthening (freezing, detonation spraying, plasma arc welding) does not meet the requirements for performance and physical and mechanical properties of the working parts (adhesion cover with the base, wear resistance, hardness, toughness, etc.). .

Analysis of modern ideas about the kinds of wear shows that working bodies of agricultural machines undergo these types of destruction: abrasive - as a result of cutting or scratch the impact which the solids and particulates; fatigue - as a result of fatigue during repeated deformation micro surface layer in friction sliding or rolling; oxidation - a chemical reaction with oxygen or material environment and mikroplastychnoyu deformation of the surface layer.

Fig. 1 and Fig. 2 shows the dimensions of training blade blade cultivator and legs during welding. Preparation plots surfacing in detail the type of disc harrows is correct geometry blade grinding their way to a thickness of 0.5 ... 0.7 mm at an angle of 33 to screw-cutting lathe (Fig. 3) or roughing-zahostryuvalnyh machines. In manual arc surfacing layer poured the mixture on the prepared blade melted electric arc length of 3 ... 4 mm AC or DC (direct polarity) 200 ... 250 A graphite (carbon electrode). Felling strengthening of socks: the movement of the electrode (diameter 12 ... 15 mm) must be zigzag (Fig. 4).

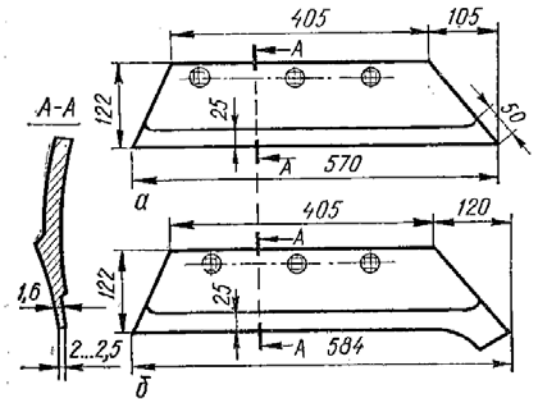

Fig. 1. Preparation for welding blade: a - direct blade; - with dolotopodibnym blade.

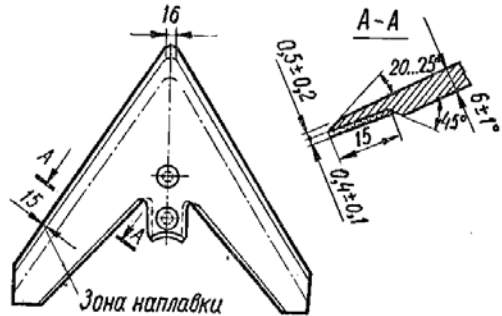

Fig. 2. Preparation paws cultivator to welding.

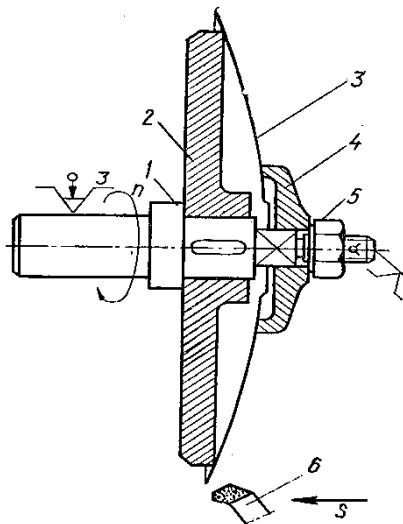

Fig. 3. Scheme grinding disc for screw-cutting lathe 1 - mandrel; 2 - swashplate; 3 - disc; 4 - Washer; 5 - nut; 6 - cutter.

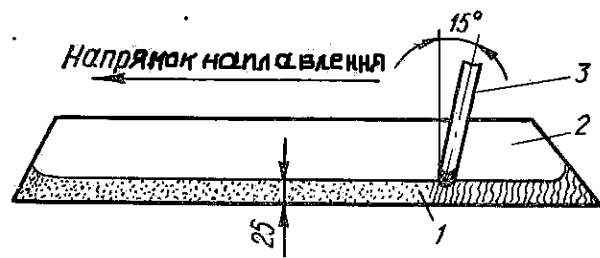

Fig. 4. Scheme arc welding blades powdered hard alloy blade 1 - charge; 2 - ploughshare; 3 - Graphite electrode.

Induction welding method is more productive than manual gas and electric arc surfacing. Heat the mixture and blades made by high frequency of 500 to 100,000 Hz. The rate of heating at the specified frequency range is 1.5 ... 6 minutes. The depth of heating is 5 mm (Fig. 5: 1 - coolant 2 - detail that strengthen 3 - charge 4 - inductor odnovytkovyy.). The essence of plasma welding blades tillage machines parts is that the current arc plasma blown powdered hard alloy (FBH-6-2 mark "Sormayt-1"), which it melts, and as the melt enters the bearing surface of the blade (Figure . 6: 1 - ploughshare 2 - weld hard alloy 3 - protective kerosene (nitrogen) 4 - working curve 5 - additional arc 6 - powdered hard alloy, 7 - water, 8 - channel for cooling water 9 - plasma utvoryuvalnyy kerosene, 10 - tungsten electrode, 11 - current source.).

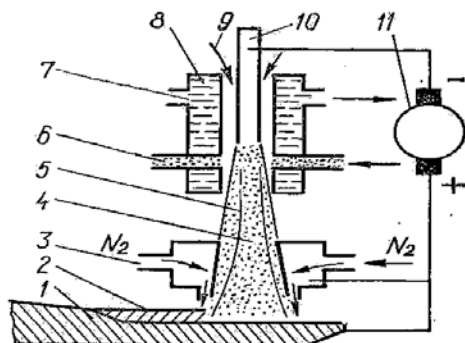

Fig. 5. Scheme induction welding powdered hard alloy.

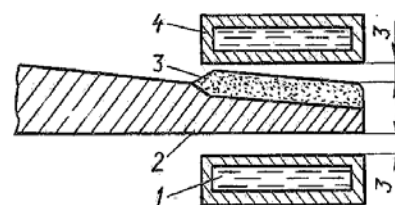

Fig. 6. Scheme plasma deposition.

Modes plasma deposition, the current strength of the working and supporting arches respectively 180 and 80 A; working voltage, and idle auxiliary arc respectively 60, 25 and 100 V; costs plasma forming gas (argon), transports (nitrogen) and protective (nitrogen), respectively, 3, 6 and 10 l / min .; welding speed 0,002 ... 0,003 m / s (150 ... 180 mm / min.); expenses powder 3 ... 5 kg / h. The method of increasing melt carbide is that the surface of the blade to be strengthening, moistened powdered flux AN-348A, and introduced into the high-frequency inductor units for melting and heat flux blade. Time shutter blades melt 2 ... 3 seconds. (Fig. 7), while building no melt mixing with a soft bearing layer blade. Scheme magnetolectric strengthening process is applied to electric-ferromagnetic powders (iron boron, ferrochrome, ferrotitanium and other) or powder compositions in magnetic field (Fig. 8).

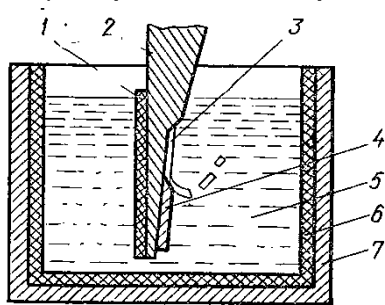

Fig. 7. Scheme extension carbide blades melt 1 - isolation; 2 - blade; 3 - molten flux; 4 - stackable layer; 5 - melt carbide; 6 - fireproof insulation baths; 7 - bath.

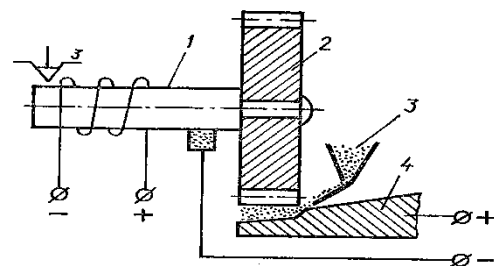

Fig. 8. Scheme magnetolectric strengthening process: 1 - electromagnetic head 2 - tools; 3 - feroporoshok; 4 - ploughshare.

Modes strengthening electric-mode, the discharge current 100 ... 120 A; voltage, 24 ... 36 V; Magnetic induction - 0,3 ... 0,8 T; working gap value - 2.5 ... 3.5 mm; Grain size - 0,2 ... 0,6 mm. Performance Process - 60-70 cm² / min at the speed of powder supply 10 ... 15 g / min. The thickness of the coating reaches 0,5 ... 1,5 mm.

The purpose of research is the study of changes in the state laws and durability of construction materials and wear-resistant coatings to abrasion wear the example of workers tillage machines.

Results. Arc spot welding (TPA), which is used to improve the wear resistance of tillage machines based on mikrovkraplenni carbide in the structure of surfaces that undergo abrasive wear [5, 6]. The process is carried out by technology developed in conjunction with scientists from the Institute of Electric them. Paton NAS of Ukraine. Points strengthen formed by the rapid introduction of metal parts such as heat, which is necessary for penetration cone crater filling it with molten base metal and carbide strengthening and movement points. The wide bowl-shaped crater cone geometry facilitates the rapid removal of heat from the bath

surfacing in the base metal and the environment, so in terms cooled at high speed and in a short time. Resistance TPA and strengthening the basic parameters of the point - form depth h_2 of penetration, height and diameter D_n h_1 surfacing weld depend on $I_s.v.$ current, voltage U_d arc diameter d_E and speed v_n supply wire mode DTZ, as well as on the brand and type of heat treatment of metals, the thickness H strengthening details and polarity current (Fig. 9).

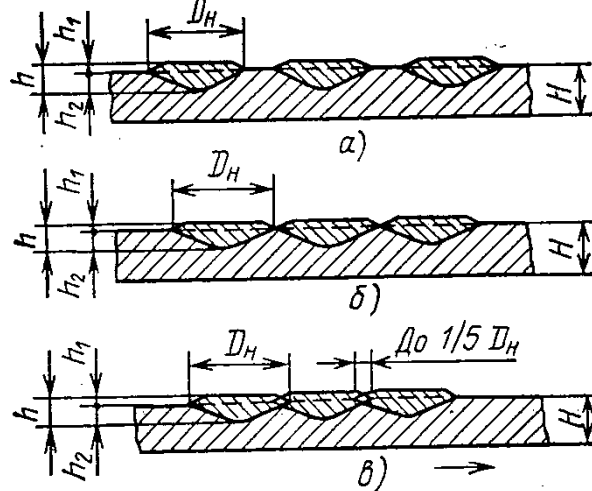

Fig. 9. Settings strengthening points: a - local; b - compatible; in - conjugated.

Direct current polarity reduces resistance arc process leads to the formation of spray reduces the depth of penetration and increases the height of the head in terms of strengthening. The mode DTZ arc spot welding practiced in reverse polarity. The depth of penetration should provide permanent connection reliability in terms of strengthening the base metal at its abrasion and outcrop of hard metal until the rejection criterion will be received by the working body wear.

H_2 depth of penetration as more options to strengthen a point (D_n , h_1), achieved by adjusting the strength of the weld current, voltage and time of the arc. Welded current has the greatest influence on shaping terms of strengthening: *vyzyvaye* increase its growth and penetration depth h_2 diameter D_n head point and reduce the height h_1 surfacing. Thus, with the increase of welding current from 400 to 650 and the diameter D_n increases from 14.5 to 31 mm, h_2 - from 2.3 to 4.3 mm and the height h_1 deposition decreased from 3.5 to 1.2 mm.

Optimal height in terms of strengthening (head height) choose depending on the functional purpose of the working body of the agricultural machine. It must ensure the protection of the base metal from abrasive wear. Height terms of strengthening should be such as to defend the worn surface without creating significant resistance to movement of the working body in the ground. In plowing blade, such as

welding Blade height should not exceed 2 mm, and at loggerheads vineyard machine - 0,5 mm, or increases traction resistance is sticky soil and agronomic requirements are not met by cutting weeds [7, 8] . The diameter of the head points to strengthen in line with the selected option of their location, which is determined by the nature of the deterioration of the working body can determine the height h_1 head and a depth h_2 proplavlyannya, defined taking into account the thickness of parts and agronomic requirements, the diameter d_E and length l cored wire used in terms of strengthening education. Experiments show that the number of road vehicles should be considered as the base metal, and cored wire, forming a point to strengthen by means of appropriate coefficients k_m and K_P , which reflect the ratio of core and metal carbide in total weld point. This allows the entire proplavlyaty blade thickness, which is important for samozahostroyuvannya plowshares, because wear increases in the difference between the hardness of the weld and weld areas and not the operation as a result of the Third Kind samozahostroyuvannya formed stepwise wavy-edge (Fig. 10).

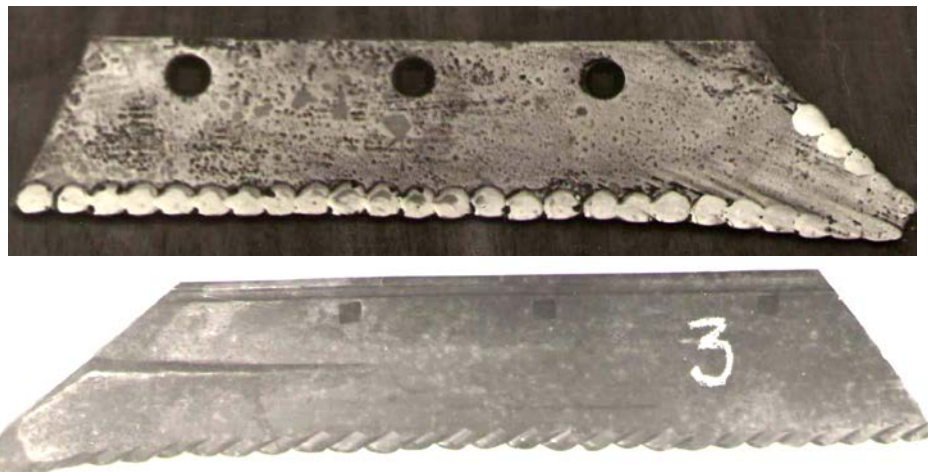

Fig. 10. plowshare plow operating time after 49.0 hectares.

Technological parameters point to strengthen and mode DTZ worked and standardized for these working bodies tillage machines subjected to strengthen (Table. 1): Plowshares and flat steel L53, field boards, sidewalls, chisel cultivators with steel 45, ripping legs and knives cultivators , chisel plows and naralnykiv Ripper 65G steel, sternum shelves with shelves of a three-layer steel.

For welding points used to strengthen Carbide Powder Self-wire (PE AN-170) PE-CO-80H20R3T-N-C 3.2 (GOST 26101-84), which provides a surface hardness of 60-65 NRSe blade. Before flux cored wire for removal of moisture dried at a temperature of 200-250°C. for 40 minutes, and parts cleaning corrosion, oil and dirt. The presence of the

normal scale layer after drying does not affect the quality point of strengthening.

1. Modes strengthening welding points.

Name details	arson arc	penetration	Forming heads	$AND_{St.A}$	U_d, B	$t, \text{ with}$	Departure electrode, mm
	$t_{1,2,3}$	$vp_{1,2,3} \text{ mm / s}$					
Sides:							
PLZH 51.200U	0.5 / 17	2.1 / 96	0.4 / 21	620-660	38-43	3	27
PHTS 61.200U	0.5 / 17	1.6 / 44	0.4 / 21	650-700	42-45	2.5	27
PLYE 21,500 Belly shelf							
PLYE 21.401U	0.4 / 17	1.9 / 69	0.4 / 21	510-560	32-36	2.7	23
Ploughshare							
PNCHS 702U: toe	0.4 / 17	1.6 / 44	0.4 / 21	570-620	35-39	2.5	27
blade	0.5 / 17	2.1 / 96	0.4 / 18	620-650	39-42		
Knife KFH 06.070U	0.4 / 17	1.9 / 69	0.4 / 18	650-700	42-45	3	27
Paws:							
KFH 00.070U				700-620	45-38	2.7	23
8.5 (GOST 1343-82)				640-510	40-32		
				560	36		

Spot strengthening carry on the details in a horizontal or close positions. Resistance excitement arc welding performance and determine the mode DTZ. Relatively stable arc excitation is provided with a current density of at least 150 A / mm². At the same current density higher voltage power supply idle pace creates more favorable conditions for excitation and arcing. Experiments show that when surfacing between the end point and further arc excitation are no more than 5-7 seconds, the end of the electrode does not have time to cool down and subsequent inflammation occurs without difficulty. Great value for arson arc has an initial feed rate cored wire: at $vp_1 > 80 \text{ m / h}$. arc excitation is repeated 1-2 times at strengthening 100 points, while $vp_1 > 100 \text{ m / h}$. much less frequently. It was established that the optimal speed vp_1 is within 30-70 m / h.

Surfacing is recommended at maximum current density. The average power efficiency of road vehicles with a power source that is 85%, ranging from 15 to 40 kW [9, 10].

DOT DEFECTS strengthening may be pores in the deposited layer, the unevenness of the head, burning parts without penetration, are easily detected by external examination. Clad in points allowed out without some cracks in the base metal parts. The presence of TPA spray on the surfaces does not affect its functional properties.

Indirect no sign penetration - understated and unstable diameter point. To prevent phenomena need to control current and voltage. The sign of a good quality color surfacing surfacing serve on the back of the details.

Such defects as the low point of the head unit and pores virtually no effect on the durability of the work. Is unacceptable defects that reduce the strength of the details (burning and crack in the base metal) and wear resistance (lack of penetration).

Cultivating machines with working bodies, firm DTZ, were field tested in the 1983-1990 biennium. And 2004-2014 years. In different soil and climatic zones of Ukraine. Spot strengthening compared with induction welding increases the wear resistance of the working bodies of 1.5-3 times, while their production costs are reduced due to a significant decrease in power consumption (5 times more), 4-5 times increases productivity significantly declining industrial areas. Points surfacing appear above the face details on the value of 1 ... 3 mm and penetrating the base metal to a depth of 4 ... 6 mm, forming on the surface of the face parts Carbide point diameter 18 ... 25 mm and hardness NRS 60 ... 66 (Fig. 10 Fig. 11).



Fig. 11. Geometrical points strengthening.

Direct current polarity reduces the stability of the process leads to the formation of spray reduces the depth of penetration and increases the height of the point of hardening. Therefore parameters point worked on strengthening inverse polarity. Welded current has the greatest influence on shaping opinions strengthening. For example, with increasing weld current from 400 to 650 A, in terms of strengthening the diameter increases from 14.5 to 31 mm, height of 2.3 to 4.3 mm, and height surfacing reduced from 3.5 to 1.2 mm[6]. The required depth of

penetration as more options to strengthen spot weld is achieved by changing the strength of current, voltage and arc length. Plowing was carried out at a depth of 25 ... 27 cm after harvesting crops. During the tests performed regularly measure the parameters of the job, to determine the value of wear. All working bodies were the primary technical expertise labeled. Performance conditions and quality of work determined in accordance with GOST 20915-75 and OST.4.1-80.

Experimental Felling of strengthening point blade and bow plows are installed on serial PLN-5-35 that ahrehatuvavsya tractor T-150K. From the quality parameters of the experimental treatment plowshares depth and width correspond to the specifications. During the experimental testing ground plowshares adhesion was observed. Experimental Felling of strengthening increased wear resistance point (PNCHS-702U) meet the requirements for working the soil.

Resistivity PLN-5-35 with experimental blade at a speed of 2.08 m / s is 6.27 N / cm², which is 2.5% less (Within the measurement error) than PLN-5-35 with serial plowshare. Since the difference of specific indicators within the measurement error, the value of specific indicators units, compared, can be considered the same. By pulling power indicators tractor T-150K in the unit with PLN-5-35 with experimental blade provides a stable process performance, engine load when driving at a speed of 2.08 m / s was 94.6%.

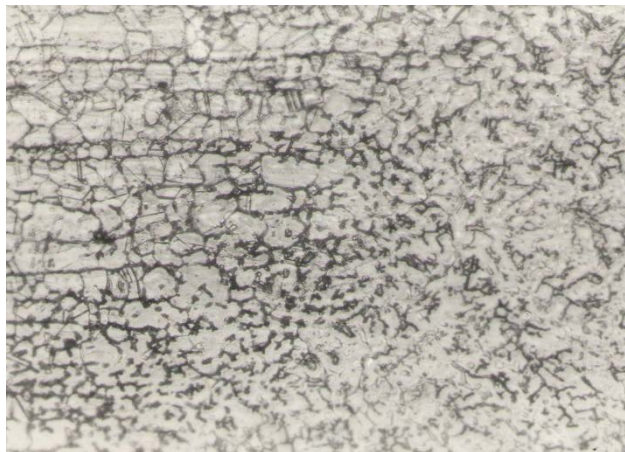

Fig. 12. The microstructure point of strengthening the blade, h250.

High durability experimental plowshares to abrasion wear provides for the structure of the deposited layer of carbides of refractory metals. The formation of carbide phase is mainly possible in two ways: through a separate carbide alloying elements and carbon alloy weld or by a complex alloying, when administered ready carbide coating compound. The second way to significantly simplify the structure adjustment of weld metal. Microstructure terms of strengthening it B₄C boron carbide (Fig. 12), boron is composed of charge, in pure form. At a point strengthening,

seeing (Fig. 13), Borides distributed grain boundaries, with no hardened structures and cracks. When using such material operational load acting mainly to the inclusion of hard-elastic plastic matrix and stress relaxation occurs.

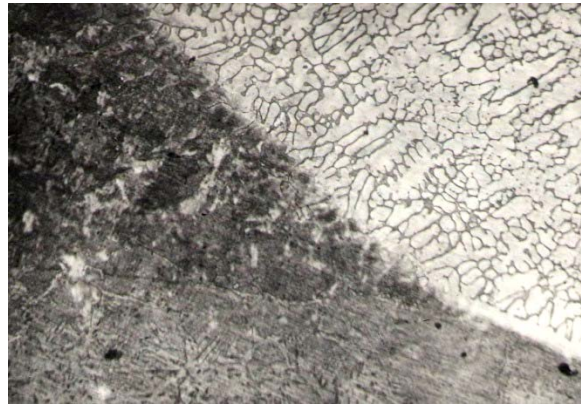

Fig. 13. Line fused with the top and middle layer blade, x 250.

Conclusions

1. Arc spot welding Self-cored wire PP-AN170 (PP-AN170M) to create a technology that provides increased durability blade point (paws cultivator) in 1.5-3 times compared with induction welding when plowing in soils with different particle size and the intensity of wear.

2. Specific advantages arc spot welding Self-cored wire PP-AN170 (AN-PP-170m) is the possibility of using this method directly in agricultural enterprises, including private farms and repair shops unlike induction welding in the factory.

3. Arc spot welding Self-cored wire allows you to make strengthening and restoration work surface edges of agricultural machines in the field, because the wind has practically no influence on the process of welding. Easy input of alloying elements in the weld layer composition is adjustable over a wide range.

4. Production tests confirmed that the blade is wear it samozahostroyvannaya due to the difference of hardness stations substrate (base metal) and the surface of the blade working body.

List of references

1. Novikov VS Provision Durability workers organs soil-cultivating machines: Author. Dis. on soys. uchenoy degree Doctor. Sc. Sciences specials. 05.20.03 - technology and of technical sredstva of service in the agricultural sector / VS Novikov. - M., 2008. - 43 p.
2. *Fundamentals* theory and calculation agricultural machines for prochnost and reliability of / Ed. P. Volkov and M. Tenenbaum. - M.: Engineering, 1977. - 260 p.
3. Tkachev VN Yznos and Increase Durability detail agricultural machines / VN Tkachev. - M.: Engineering, 1971. - 264 p.
4. GI Kiselev Abrazivnyy yznos DIFFERENT metal at temperatures and Speed / GI Kiselev. - M.: DAN USSR, 1952. - T. XXXVII. - №5. - S. 124-132.
5. A. Rosenbaum Yznashyvanye blades in pochvennoy environment / A. Rosenbaum. - M.: Mashhyz, 1960. - P. 146-152.

6. Klyuenko VN Universal samozatachyvayuschyeya pluzhnye Lemekh povyshennoy yznosostoykosty / VN Klyuenko. - M: Traktory and selhozmashyny, 1986. - P. 18.
7. I. Ermakov Samozatachyvayuschyeya chuhunnye Lemekh / I. Ermakov. - M.: Mashhyz, 1956. - S. 123.
8. Denisenko NI wear and increase durability of working organs of agricultural machines / NI Denisenko, A. Opalchuk // Science journal. - Ternopil: Ternopil Ivan Pul'uj National Technical University, 2011. - P. 201-210.
9. Denisenko NI strengthening and restoration parts vehicles and agricultural machines using protective wear-resistant coatings / NI Denisenko, VD Voytyuk, VI Rublev // Journal of Kharkov National Technical University of Agriculture. Petro Vasilenko. - Kharkiv, 2010. - Vol. 101 - P. 93-103.
10. Tereshchenko VI Features tochechnoy argument plavyaschymysya arc electrode / VI Tereshchenko, AN Sharovolsky, KA Sidorenko // Automatic welding. - 1983. - №9. - C. 51-53.
11. Krahelsky IV Trenye and yznos / IV Krahelsky. - M.: Mashhyz, 1962. - 304 c.

In Article dan Analytical overview of existing methods uprochnenyaya workers organs agricultural machines, rassmotreny Data tyrovyyh yznosah parts and machine nodes. Shown that most workers effektivnym by uprochnenyaya surfaces of parts soil-cultivating machines javljaetsja tochechnoe uprochnenye - Arc welding tochechnaya poroshkovoy provolokoy (plavyaschymysya electrode).

Rezhushnye Items yznosostoykost, abrazivnoe yznashyvanye, tochechnoe uprochnenye, Lemekh plow.

In paper present introduce the present method hardening working tool cultivation machine them advantage and defect Demonstrate what the greatest effective method hardening force surface part cultivation machine have-point hardening point consumable-electrode are welding flux cored electrode.

Cutting elements, wear resistance, abrasive wear, point hardening, blade share.

UDC 631.3: 62-231.3

Kinematic aspects of WORK threaded connection AGRICULTURAL MACHINERY

***Yakov Mikhailovich Ph.D.
National University of Life
Ukraine and Nature
AM scar, Ph.D.***